



# BROAN - EZ FIT SERIES- BATHROOM FAN - SPECIFICATION SHEET

## NuTone®

SPECIFICATION SHEET

### MODEL EZ80N EZ FIT VENTILATION FAN

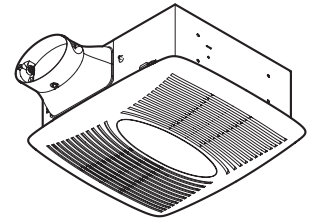

#### DESCRIPTION

##### BLOWER:

- Plug-in, permanently lubricated motor - engineered for continuous operation
- Dynamically balanced centrifugal blower wheel for quiet, efficient performance
- Low RPM for quiet operation

##### HOUSING:

- Rugged, galvanized steel construction
- Metal, 4" oval duct connector with no metallic clatter
- Includes 4" oval to 3" round duct reducer
- 5" height allows for installation in 2x6 ceiling framing
- Ideal installation uses four tightening clamps that twist to secure housing directly to ceiling material *(See illustration at right)*
- Alternative installation allows housing to be directly attached to ceiling joists or trusses
- Can be mounted in flat ceilings or sloped ceilings up to 12/12 pitch

##### GRILLE:

- Polymeric construction
- Innovative design - the result of extensive research with designers and consumers

##### CONTROLS (Purchase separately):

- Refer to NuTone's catalog for a complete line of accessories to effectively adapt this fan to your construction requirements.

U.L. Listed for use over bathtubs and showers when connected to a GFCI protected branch circuit (ceiling mount only).

1-Year Warranty

#### TYPICAL SPECIFICATION

- Fan shall be NuTone Model EZ80N.
- Fan shall have corrosion resistant galvanized steel housing. It shall be ducted to a roof or wall cap using 4" or 3" round ductwork.
- Blower assembly shall be removable, have a centrifugal-type blower wheel and a permanently lubricated motor designed for continuous operation.
- Metal damper/duct connector shall be included.
- Air delivery shall be no less than 80 CFM and sound level no greater than 1.0 Sones. All air and sound ratings shall be certified by HVI.
- Fan shall be ENERGY STAR® qualified and have an energy efficient permanent split capacitor motor.
- Fan shall be U.L. Listed for use over bathtubs and showers when connected to a GFCI protected branch circuit (ceiling mount only).

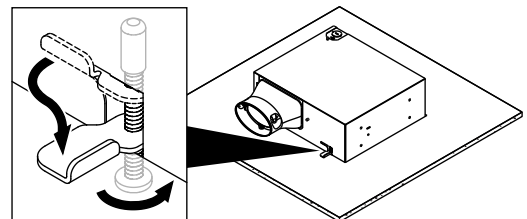

Broan-NuTone LLC Hartford, Wisconsin www.nutone.com 888-336-3948

REFERENCE	QTY.	REMARKS	Project
			Location
			Architect
			Engineer
			Contractor
			Submitted by <span style="float: right;">Date</span>

51H 99045459A



#2 Chootoo Road, South Aranguez, San Juan, Trinidad





# BROAN - EZ FIT SERIES- BATHROOM FAN - SPECIFICATION SHEET

## PERFORMANCE RATINGS MODEL EZ80N EZ FIT VENTILATION FAN

### HVI PERFORMANCE

4" Duct			3" Duct				
0.1 Ps - Static Pressure (inH <sub>2</sub> O)		0.25 Ps	0.1 Ps - Static Pressure (inH <sub>2</sub> O)		0.25 Ps		
Airflow (CFM)	Sound (Sones)	Power (Watts)	Airflow (CFM)	Airflow (CFM)	Sound (Sones)	Power (Watts)	Airflow (CFM)
80	1.0	25.7	61	70	1.3	25.0	55



HVI-2100 CERTIFIED RATINGS comply with new testing technologies and procedures prescribed by the Home Ventilating Institute, for off-the-shelf products, as they are available to consumers. Product performance is rated at 0.1 in. static pressure, based on tests conducted in a state-of-the-art test laboratory. Sones are a measure of humanly-perceived loudness, based on laboratory measurements.

### AMPS

Model	Amps
EZ80N	0.3

### WEIGHT

Model	Shipping Weight
EZ80N	9.6 lbs.

### AIR FLOW PERFORMANCE

MODEL EZ80N - 4" DUCT

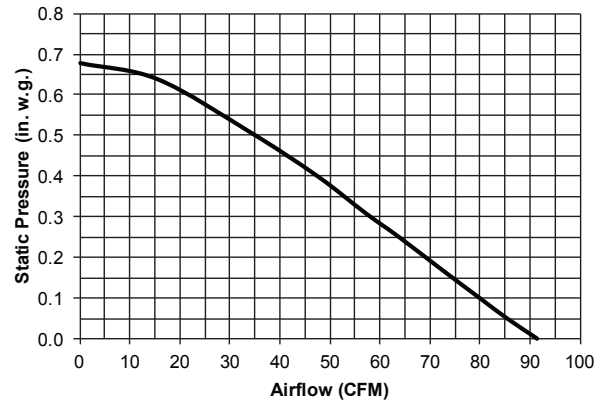

MODEL EZ80N - 3" DUCT

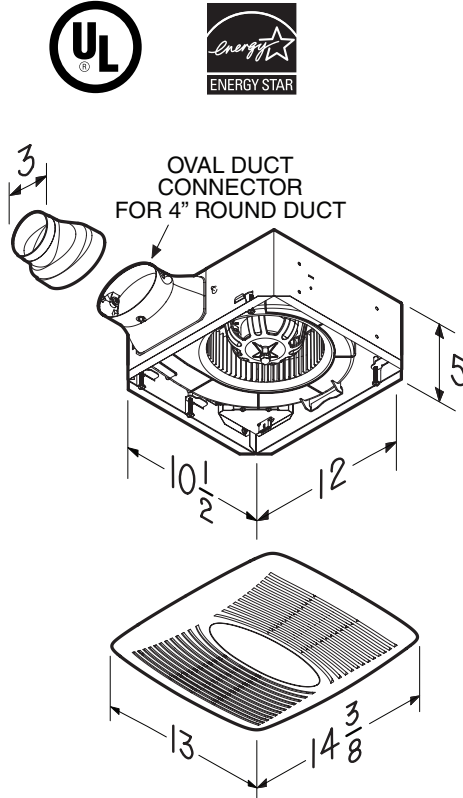
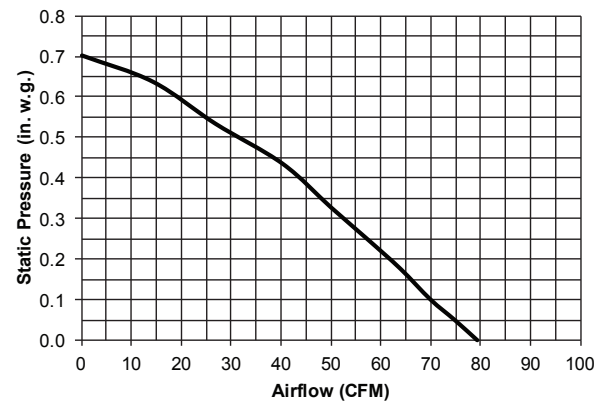

**NuTone**

Broan-NuTone LLC Hartford, Wisconsin www.nutone.com 888-336-3948



#2 Chootoo Road, South Aranguéz, San Juan, Trinidad

