



# BROAN - SENSONIC SERIES - BATHROOM FAN SPECIFICATION SHEET



## SPECIFICATION SHEET

### MODEL SPK80L FAN/LIGHT/SPEAKER

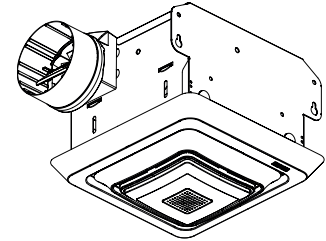

**Quiet heavy duty ventilators built with high performance blowers.**

**FEATURES**

**GRILLE:**

Matte white polymeric - blends well with any decor  
Sturdy light-diffusing lens

**BLOWER:**

Plug-in, permanently lubricated, totally enclosed motor  
Centrifugal blower wheel for quiet, efficient performance  
Long life motor bearings  
Designed for continuous operation

**HOUSING:**

Rugged, 26-gage galvanized steel construction  
Integral key-holed mounting brackets for easy, secure installation directly to joist  
Provision for wire suspension when installed in a drop ceiling  
Tapered, polymeric duct fitting with built-in backdraft damper for easy, positive duct connection and no metallic clatter

**LIGHT/SPEAKER MODULE**

LED light module with integrated speaker. Play any audio from most *Bluetooth*® enabled devices.

NOTE: For installation in ceilings up to 12/12 pitch

U.L. Listed for use in insulated ceilings (Type I.C.)  
U.L. Listed for use over bathtubs and showers when connected to a GFCI protected branch circuit  
Use supply wiring rated for at least 90°C

**TYPICAL SPECIFICATION**

Fan/Light/speaker unit shall be Broan model SPK80L.

Unit shall have galvanized steel housing with integral mounting brackets. Unit shall have built-in backdraft damper and shall be ducted to a roof or wall cap.

Motor to be totally enclosed, permanently lubricated, and have long-life bearings designed for continuous operation. Blower assembly shall have a centrifugal blower wheel and be removable from housing.

Air delivery shall be no less and sound level no greater than values listed in the "Performance Ratings" charts on this sheet. All air and sound ratings shall be certified by HVI.

Unit shall be U.L. Listed for use over bathtubs and showers when connected to GFCI protected branch circuit.

Unit shall be U.L. Listed for use in insulated ceilings (Type I.C.).



Broan LLC Hartford, Wisconsin [www.broan.com](http://www.broan.com) 888-558-1711  
Venmar Ventilation ULC Drummondville (Quebec), Canada [www.broan.ca](http://www.broan.ca) 877-896-1119

REFERENCE	QTY.	REMARKS	Project
			Location
			Architect
			Engineer
			Contractor
			Submitted by Date

91C 1102559A



#2 Chootoo Road, South Aranguez, San Juan, Trinidad





# BROAN - SENSONIC SERIES - BATHROOM FAN SPECIFICATION SHEET

## PERFORMANCE RATINGS - MODEL SPK80L

### HVI PERFORMANCE

Model	Static Pressure (Ps)	CFM	Sones
SPK80L	0.10	80	2.5

### WEIGHT

Model	Shipping wt
SPK80L	6.7 lb

### ELECTRICAL

Model	Volts	Hz	Amps*
SPK80L	120	60	0.50

\*Total connected load

### LIGHTING

Model	Lighting output (Lumens)	Correlated Color Temperature (CCT)	Color Rendering Index (CRI)	Efficacy (Lumens/Watt)	Rated Life (Hours)	Dimming Compatible
SPK80L	600+	3000K	80	50	25 000	No



### SPEAKER

Model	Power (Watts)	Connectivity	Range (Feet/meters)
SPK80L	4	Bluetooth® 5.0	Up to 30/9.1



HVI-2100 CERTIFIED RATINGS comply with new testing technologies and procedures prescribed by the Home Ventilating Institute, for off-the-shelf products, as they are available to consumers. Product performance is rated at 0.1 in. static pressure, based on tests conducted in a state-of-the-art test laboratory. Sones are a measure of humanly-perceived loudness, based on laboratory measurements.

The Bluetooth® word mark and logos are registered trademarks owned by Bluetooth® SIG, Inc. and any use of such marks by Broan LLC is under license. Other trademark and trade names are those of their respective owners.

NOTE: This equipment has been tested and found to comply with the limits for a Class B digital device, pursuant to Part 15 of the FCC Rules. These limits are designed to provide reasonable protection against harmful interference in a residential installation. This equipment generates, uses and can radiate radio frequency energy and, if not installed and used in accordance with the instructions, may cause harmful interference to radio communications. However, there is no guarantee that interference will not occur in a particular installation. If this equipment does cause harmful interference to radio or television reception, which can be determined by turning the equipment off and on, the user is encouraged to try to correct the interference by one or more of the following measures:

- Reorient or relocate the receiving antenna.
- Increase the separation between the equipment and receiver.
- Connect the equipment into an outlet on a circuit different from that to which the receiver is connected.
- Consult the dealer or an experienced radio/TV technician for help.

This device complies with Part 15 of the FCC Rules and RSS-210 of Canada. Operation is subject to the following two conditions:

(1) This device may not cause interference, and (2) this device must accept any interference received, including interference that may cause undesired operation. FCC ID: 2ADLL-1102136 IC IDs: 2143B-1102136

This Bluetooth® wireless technology enabled luminaire complies with FCC radiation exposure limits set forth for an uncontrolled environment. End users must follow the specific operating instructions for satisfying exposure compliance. This luminaire must not be co-located or operate in conjunction with any other antenna or transmitter.

Changes or modifications not expressly approved by the party responsible for compliance could void the user's authority to operate the equipment.

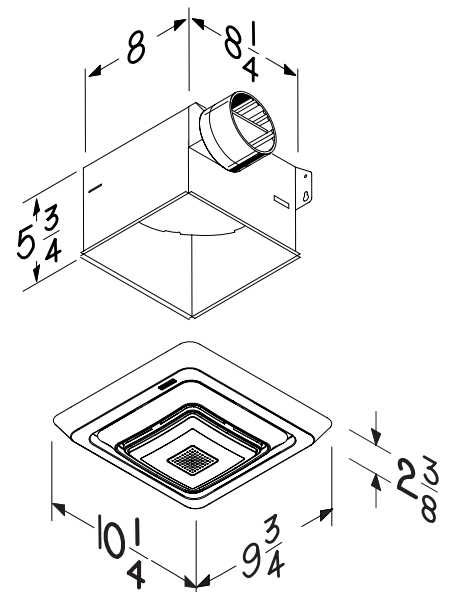
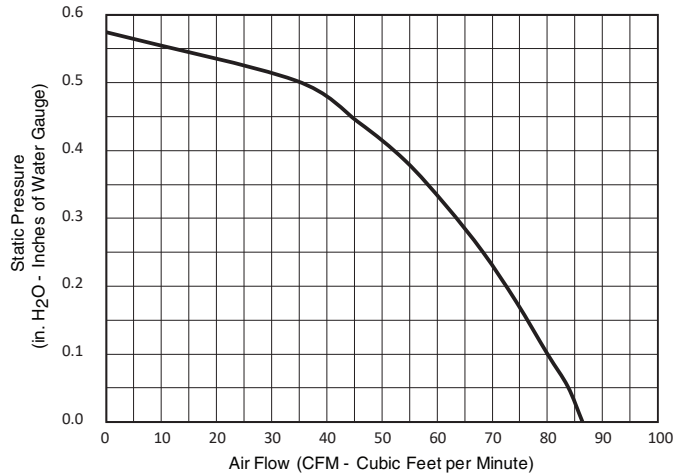

Dimensions shown in inches



Broan LLC Hartford, Wisconsin [www.broan.com](http://www.broan.com) 888-558-1711  
Venmar Ventilation ULC Drummondville (Quebec), Canada [www.broan.ca](http://www.broan.ca) 877-896-1119



#2 Chootoo Road, South Aranguéz, San Juan, Trinidad





# BROAN - SENSONIC SERIES - BATHROOM FAN SPECIFICATION SHEET

## BROAN®

SPECIFICATION SHEET

### MODEL SPK110 SPEAKER FAN

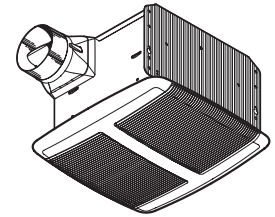

#### DESCRIPTION

**BLOWER:**

- Plug-in, permanently lubricated motor - engineered for continuous operation
- Dynamically balanced centrifugal blower wheel for quiet, efficient performance
- Low RPM for quiet operation

**HOUSING:**

- Rugged, galvanized steel construction
- Polymeric, 4" round duct connector with tapered sleeve and no metallic clatter
- 7-5/8" height allows for 2" x 8" ceiling installations
- Sturdy, easy, four-point mounting directly to joist
- Includes unique, patented spacer for mounting to engineered "I" joists
- Can be mounted in ceilings up to 12/12 pitch

**GRILLE:**

- Polymeric construction
- Innovative design - the result of extensive research with designers and consumers

**SPEAKER ASSEMBLY:**

- Dual High-Fidelity Sensonic™ speakers with *Bluetooth*® wireless technology
- Brilliant audio performance concealed behind the fan grille
- Play any audio through most *Bluetooth*® wireless technology enabled devices

**CONTROLS** (Purchase separately):

- Refer to Broan's catalog for a complete line of accessories to effectively adapt this fan to your construction requirements.

U.L. Listed for use over bathtubs and showers when connected to a GFCI protected branch circuit (ceiling mount only).

3-Year Warranty

#### TYPICAL SPECIFICATION

Fan shall be Broan Model SPK110.

Fan shall have corrosion resistant galvanized steel housing with four-point mounting capability. It shall be ducted to a roof or wall cap using 4" round ductwork.

Blower assembly shall be removable, have a centrifugal-type blower wheel and a permanently lubricated motor designed for continuous operation.

Speaker assembly shall be removable and play audio files when paired with most *Bluetooth*® wireless technology enabled devices.

Non-metallic damper/duct connector shall be included.

Air delivery shall be no less than 110 CFM and sound level no greater than 1.0 Sone. All air and sound ratings shall be certified by HVI.

Fan shall be ENERGY STAR® qualified and have an energy efficient permanent split capacitor motor.

Fan shall be U.L. Listed for use over bathtubs and showers when connected to a GFCI protected branch circuit (ceiling mount only).



The *Bluetooth*® word mark and logos are registered trademarks owned by Bluetooth SIG, Inc. and any use of such marks by Broan-NuTone LLC is under license. Other trademarks and trade names are those of their respective owners.

Broan-NuTone LLC Hartford, Wisconsin www.broan.com 800-558-1711  
Broan-NuTone Canada ULC Mississauga, Ontario www.broan.ca 888-882-7626

REFERENCE	QTY.	REMARKS	Project
			Location
			Architect
			Engineer
			Contractor
			Submitted by <span style="float: right;">Date</span>

51H 99045472A



#2 Chootoo Road, South Aranguez, San Juan, Trinidad





# BROAN - SENSONIC SERIES - BATHROOM FAN SPECIFICATION SHEET

## PERFORMANCE RATINGS MODEL SPK110 SPEAKER FAN

### HVI PERFORMANCE

Model	Static Pressure (Ps)	CFM	Sones	Fan Watts
SPK110	0.10	110	1.0	31.4
	0.25	90		



HVI-2100 CERTIFIED RATINGS comply with new testing technologies and procedures prescribed by the Home Ventilating Institute, for off-the-shelf products, as they are available to consumers. Product performance is rated at 0.1 in. static pressure, based on tests conducted in a state-of-the-art test laboratory. Sones are a measure of humanly-perceived loudness, based on laboratory measurements.

### AIR FLOW PERFORMANCE

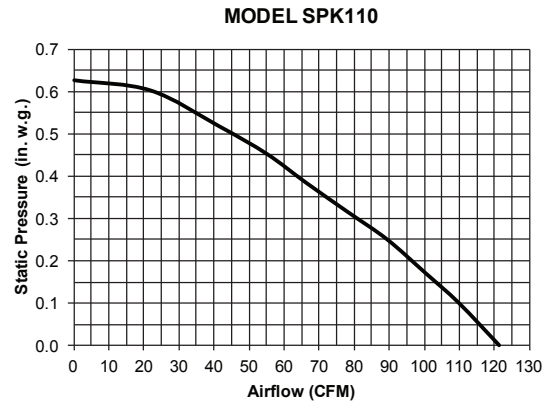

### AMPS

Model	Amps*
SPK110	0.9

### WEIGHT

Model	Shipping Weight
SPK110	11.7 lbs.

\* Total connected load.

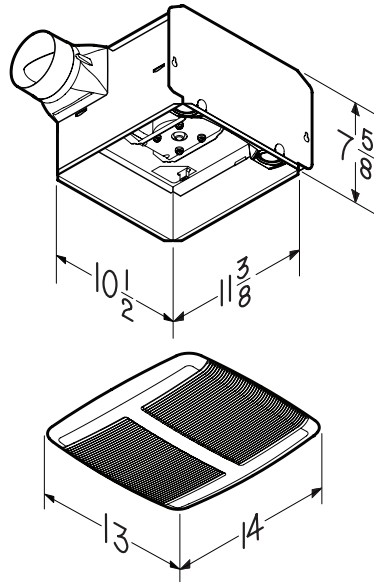

Broan-NuTone LLC Hartford, Wisconsin [www.broan.com](http://www.broan.com) 800-558-1711  
Broan-NuTone Canada ULC Mississauga, Ontario [www.broan.ca](http://www.broan.ca) 888-882-7626



#2 Chootoo Road, South Aranguéz, San Juan, Trinidad

