



SEIHO - SFB - DRYER VENT SUBMITTAL SHEET



SUBMITTAL SHEET
www.seiho.com

Model: SFB

Dryer Vent

- Standard with Flapper Damper
- Large Free Area Reduce Clogging
- All Aluminum Construction

- Material: Aluminum
- Standard Finish: Clear Anodized

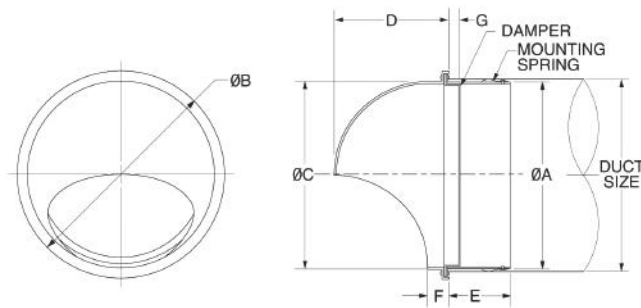

MODEL	DUCT SIZE	A	B	C	D	E	F	G	FREE AREA
SFB 4	4"	3 19/16	4 3/4	3 25/32	2 11/16	1 9/16	13/16	5/16	0.054sq.ft
SFB 6	6"	5 23/32	6 29/32	5 29/32	3 15/16	2 9/16	27/32	11/32	0.13sq.ft

Product information is subject to change without notice. All dimensions in inches.

JOB NAME: _____	SUBMITTED BY: _____	DATE: _____	Model SFB Dryer Vent
LOCATION: _____			
ARCHITECT: _____			Form No.422-22B
ENGINEER: _____			
CONTRACTOR: _____			

P.O.Box 91813 Pasadena, CA 91109 U.S.A. Tel: (800) 248-0030 (626) 395-7299 Fax: (626) 395-7290 <http://www.seiho.com> e-mail: info@seiho.com



#2 Chootoo Road, South Aranguez, San Juan, Trinidad

